

SUPER SHREDDER®

Voracious In-line Disintegrator

The Super Shredder® in-line disintegrator reduces tough solids entrained in pipeline systems. This unit combines world class size reduction capabilities with a streamlined easy to maintain design that features only a few working elements. The Super Shredder is ideal for applications requiring a heavy-duty size reduction processor that can handle high flows with minimal headloss.

The Super Shredder utilizes a low speed and high torque action to chop, grind and shred solids into fine bits that can be easily processed by downstream equipment. It's innovative open-center spherical rotor design maintains a high percentage of open area—making this unit practically invisible to the flow. In fact, it can handle higher flows than any other in-line grinder available.

Powerful grinding capabilities

Finely Ground Output

Low Headloss

Few Moving Parts

High Flow Capability

Hardfaced Stainless Steel Cutters

As the rotating cutting edges precisely intermesh with stationary cutters at close clearance, solids are finely reduced with a scissor-like action. This unique design effectively handles round, even shaped solids as well as irregular objects.



Applications

The Super Shredder easily installs into straight through pipe systems via 150# flanges. It quickly goes to work reducing solids such as wood, rags, sludge, paper, plastics and more. The Super Shredder stops pumps and valves from ragging and plugging; protects filter presses from expensive punctures and incomplete de-watering, enhances and protects centrifuge operation and more. It can process waste sludge, agglomerates, oil solids, animal waste, paint sludge, pulp and paper, tannery waste, fish scrap and more.

**Franklin
MILCH**
THE SIZE
REDUCTION
SPECIALISTS

(973) 535-9200 • Fax (973) 535-6269

Construction:

With only two cutting elements, the Super Shredder's construction and maintenance is greatly simplified. The cutters are constructed of T316 stainless steel with a heavy fused coating precisely applied to all cutting surfaces. These corrosion resistant cutters provide long dependable service in abrasive service without the embrittlement associated with hardened alloys. With its bi-directional cutters, wear is further reduced via automatic reversing of the unit's direction of rotation.

Two convenient cartridges house the unit's seals and bearings. Each cartridge consists of a primary seal, a severe duty mechanical seal, oil seal, heavy duty tapered roller bearings and stub shaft. This seal design has proven highly dependable and easy to maintain.



TO THE RESCUE:

A correctional institution had a problem with plugging of their pump systems. The inmates would intentionally flush large solids including aluminum cans into the sewage system. The solution was the installation of a Model SS1200 Super Shredder. This unit alleviated pump failures and system backup. To quote the plant maintenance supervisor, "The Super Shredder solved a big problem for us. Without it our system would fail in a matter of hours so we really can't be without it."

Options

- Submersible Motor
- Guide Rails
- All Stainless Construction
- Low Flow Configuration
- DIN Flanges
- Special Purpose Seals



An arsenal of Super Shredders protects a major metropolitan wastewater facility.



Super Shredder in sludge re-circulation line.



Model 2400 Super Shredder with 24" flanges.

Configurations:

The Super Shredder is provided with a cylindrical interior housing to closely match the connected piping for optimized flow.

A direct-coupled heavy duty gear drive provides the unit's smooth, low-speed, high-torque rotation.

A model S250 Automatic Reversing Controller is supplied with the unit that senses jam conditions

and automatically reverses the bi-directional cutters. Additionally, the controller periodically reverses the operation of the unit with each restart—to maximize cutter longevity.

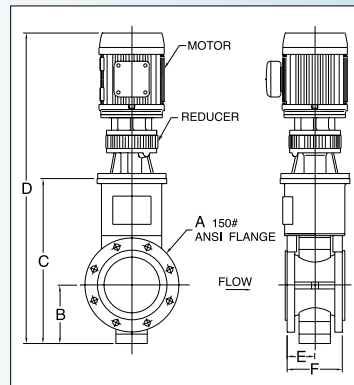

MODEL#	HP	A	B	C	D	E	F	WEIGHT
4-8000	3	4 (102mm)	8.44 (214mm)	23.75 (603mm)	45.75 (1162mm)	15* (381mm)	30* (762mm)	560 (1232kg)
6-8000	5	6 (152mm)	8.44 (214mm)	23.75 (603mm)	45.75 (1162mm)	13* (330mm)	26* (660mm)	560 (1232kg)
8000	5	8 (203mm)	8.44 (214mm)	23.75 (603mm)	45.75 (1162mm)	4 (102mm)	8 (203mm)	500 (1100kg)
1000	7.5	10 (254mm)	9.125 (635mm)	25 (232mm)	52.875 (1343mm)	8 (203mm)	13 (330mm)	600 (1320kg)
1200	10	12 (305mm)	11.56 (294mm)	32.125 (816mm)	61.5 (1562mm)	6 (153mm)	12 (305mm)	800 (1760kg)
1600	10	16 (407mm)	15.31 (389mm)	40.44 (1027mm)	69.875 (1775mm)	8 (203mm)	16 (407mm)	1800 (3960kg)
1800	15	18 (457mm)	16.75 (426mm)	42.56 (1081mm)	74.875 (1902mm)	9 (229mm)	18 (457mm)	2500 (5500kg)
2400	20	24 (610mm)	21.625 (549mm)	55.625 (1413mm)	91.19 (2316mm)	12 (305mm)	24 (610mm)	3500 (7700kg)

*Dimensions include flange adapters (not shown).

Call one of our customer service representatives to discuss your particular application.